

The ultimate filtration & drying technology

## Medical Vacuum



**Alpha Series medical vacuum filters are specially designed to protect plant installations from liquid, solid and bacterial contamination.**

1/4" to 3" threaded housings are manufactured in robust cast aluminium alloy with a corrosion protective Walker E-Coat™ finish. Intelligent, modular design ensures optimum flows, ease of installation and multiple close coupling. DN80 to DN150 flanged housings are fabricated in carbon steel with a polyester protective coating.

### Intelligent, unique, modular design

Intelligent element design constructed in oleophobic borosilicate media and an open cell reticulated foam pre filter. Unique material construction minimises pressure drop delivering reliable filtration with improved energy efficiency.

### Custom engineered filter media for optimised performance

Unique drop-fit element engages with the bowl to prevent vibration, improve stability and drainage. Designed to EN 286-1 and compliant to PED (97/23/EC) and SPVD (87/404/EEC).

### Exceeds the requirements of UK Health Technical Memorandum 02-01



BETASOLUTIONS BVBA  
Veerstraat 1A  
B-9800 Sint-Martens-Leerne (Deinze)



#### Applications include

Dental

Medical

Veterinary



THE QUEEN'S AWARDS  
FOR ENTERPRISE:  
INTERNATIONAL TRADE  
2006



Tel : +32 (0)9 324.88.63  
Fax : +32 (0)9 324.88.69  
info@betasolutions.eu  
www.betasolutions.eu



# Technical Specification

filter model	pipe size	flow rate*		dimensions (mm)				weight Kg	element model	no. of elements
		Nm <sup>3</sup> /h	SCFM	A	B	C	D			
A028 MV	1/4	3.5	2.1	70	25	191	85	0.6	E0406 MV	1
A038 MV	3/8	5	2.9	70	25	191	95	0.6	E0407 MV	1
A058 MV	1/2	7	4.1	70	25	232	135	0.7	E0413 MV	1
A059 MV	1/2	12	7.1	100	35	276	155	1.6	E0613 MV	1
A078 MV	3/4	15	8.8	100	35	276	155	1.6	E0613 MV	1
A079 MV	3/4	25	14.7	100	35	396	225	2.0	E0620 MV	1
A108 MV	1	33	19.4	100	35	396	225	2.0	E0620 MV	1
A109 MV	1	45	26.5	100	35	396	275	2.0	E0625 MV	1
A128 MV	1 1/4	60	35.3	122	42	460	320	2.8	E0730 MV	1
A158 MV	1 1/2	70	41.2	122	42	460	320	2.8	E0730 MV	1
A159 MV	1 1/2	95	55.9	146	52	482	325	4.2	E0830 MV	1
A208 MV	2	120	70.6	146	52	482	325	4.2	E0830 MV	1
A209 MV	2	175	103	146	52	785	630	6.3	E0860 MV	1
A254 MV	2 1/2	190	112	210	66	595	410	8.5	E1140 MV	1
A340 MV	3	200	118	210	66	595	410	8.5	E1140 MV	1
A360 MV	3	225	132	210	66	815	630	10.5	E1160 MV	1
A390 MV	3	265	156	210	66	975	785	12	E1175 MV	1
A391 MV	DN80	330	194	450	265	1205	n/a	58	E139 MV	1
A483 MV	DN100	406	238	520	285	1245	n/a	74	E88 MV	3
A484 MV	DN100	492	289	520	285	1245	n/a	74	E88 MV	4
A686 MV	DN150	660	388	680	400	1400	n/a	165	E88 MV	6

\* Rated flow at atmospheric pressure (1 bar (a)) and 20°C

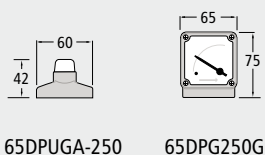

65DPUGA-250      65DPG250G

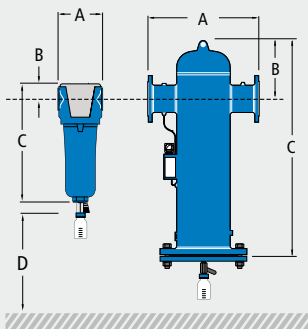

A028 MV to A686 MV

	MV	
Particle removal efficiency**	>99.995%	
Maximum temperature	60°C	140°F
Pressure loss - clean & dry	30 mbar	0.44 psi
Pressure loss - change element	100 mbar	1.5 psi
Maximum working pressure	0.5 barg	7 psig (see note 5)
Maximum working vacuum	full vacuum	
Element end cap colour	black	

\*\* In accordance with BS 3928-1969 as specified in HTM 02-01 – medical gas pipeline systems

### technical notes

- Direction of air flow is outside to in through the filter element.
- Pop up indicators (65DPUGA-250) are fitted to models A028 MV to A058 MV as standard. Differential pressure gauges (65DPG250G) are fitted to models A059 MV to A390 MV as standard. Differential pressure gauges are fitted to all flanged models.
- Manual drain valves (MDV25) are fitted to all models. Sterilisable glass drain flasks are supplied as standard, 100ml for models A028 MV to A078 MV and 250ml for A079 MV to A390 MV. An additional 1/2" side entry drain port is included on models A391 MV to A686 MV.
- Flow rates shown above are free air conditions when operating at atmospheric pressure.
- Pressure for leak testing purposes MUST be limited to 7 barg and only applied with the drain valve and drain flask REMOVED.
- Threaded and duplex filters are manufactured from cast aluminium alloy and are PED 97/23/EC compliant for group 2 gases.
- Threaded connections are Rp (BSP parallel) to ISO 7/1 or NPT to ANSI B2.1 if supplied within North America. Flanged connections are complete with mating flanges to BS4504, PN16.
- For NPT connections, add the suffix N e.g. A038MVN.
- Flanged filters are fabricated from carbon steel.
- Flanged vessels are designed and manufactured in accordance with BS EN286 and meet the Simple Pressure Vessels Directive.
- Cross port dimensions on flanged vessels are subject to a manufacturing tolerance of +/- 3mm and a squareness tolerance of 1 degree.
- Filter elements should be changed every 6 months / 1000 hours (whichever comes first).